



GENERAL PURPOSE RELAY

NRG52-SERIES

- Small size and light weight.
- Low coil power consumption.
- High contact load.
- Strong anti-shock high reliability.

SPECIFICATIONS

Contact		
Arrangement	2C □ 3C	4C
Contact Material	Silver Alloy	
Contact Resistance (By voltage drop 6V 1A)	Max. 100mΩ	
Rating		
Resistive load (Cos.Φ=1)	5A 250VAC	3A 250VAC
Inductive (Cos.Φ=0.75-0.8)	5A 28VDC	3A 28VDC
	2A 250VAC	1A 250VAC
Max. Allowable Voltage	110VDC/240VAC	
Max. Allowable Current	5A	3A
Max. Allowable Power force	600VA/150W	360VA/90W
Referencial Min.Load	10VDC 10mA	
Expected life(min.ope)		
Mechanical(at 120 cpm)	1 × 10 ⁶	
Electrical (at 20 cpm)	1 × 10 ⁵	

Characteristics		
Operate Time	Max.25 msec.	
Release Time	Max.25 msec.	
Operating humidity	45 to 85% RH	
Initial breakdown voltage		
Between coil & contact	1500VAC (50/60Hz)for 1 Min.	
Between open contacts	1000VAC (50/60Hz)for 1 Min.	
Insulation Resistance	Min.100MΩ (500 VDC)	
Ambient temperature	-40 □ ~+70 □	
Shock		
Functional Resistance	Min.10G	
Destruction Resistance	Min.100G	
Vibration		
Functional Resistance	10 to 55 Hz at double Amplitude of 1.5mm	
Destruction Resistance	10 to 55 Hz at double Amplitude of 1.5mm	
Unit weight	40g Max.	
Coil		
Nominal operating power	0.9W to 1.2VA	

TYPICAL APPLICATION

1.Industrial Machines

2.Electrical Equipments

3.Air conditioner and Household appliance

ORDERING INFORMATION

NRG51 - 2 - C - 12D - P

□ □ □ □ □

- Part No.
- Contact Poles:
1 - 1 Pole, 2 - 2 Poles, 3 - 3 Poles, 4 - 4 Poles
- Contact Arrangement:
A: Normally Open B:Normally Closed C: Change-over
- Coil Voltage:
DC: 6, 12, 24, 48, 110V
AC: 6, 12, 24, 48, 110/120, 220/240VAC
- Terminal Type: P- P.C.B. Terminal
T- Plug-in F- Plug-in with Flange Cover

COIL DATA (at 20 °C)

Type	Nominal	Normal		Coil	Power	Pull-in	Drop-out	Max.Allowable
	Voltage (VDC)	Current (mA)	50Hz					
AC	6	220	170	10	abt. 1.0 to 1.3 VA (60Hz)	80% Max.	30% Min.	110%
	12	110	85	43				
	24	60	45	160				
	48	30	23	600				
	110	14	12	3400				
	120	13.5	11.5	3400				
DC	220/240	6	5	13600	abt. 0.9W	80% Max.	10% Min.	110%
	6	150	40					
	12	75	160					
	24	36.9	650					
	48	18.5	2600					
	110	10	11000					

DIMENSIONS

Unit: mm

NRG52-2Pole Plug-in terminal

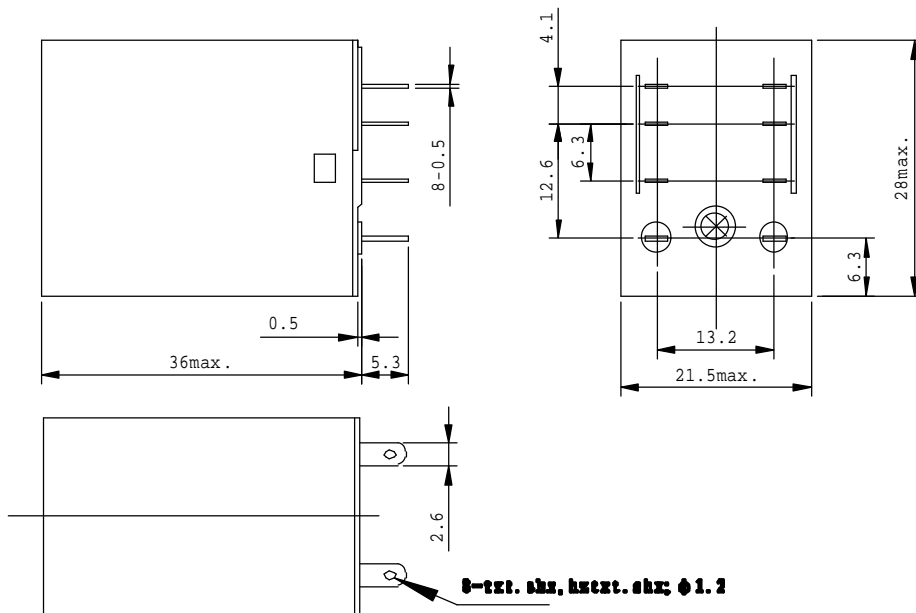

Wiring Diagram

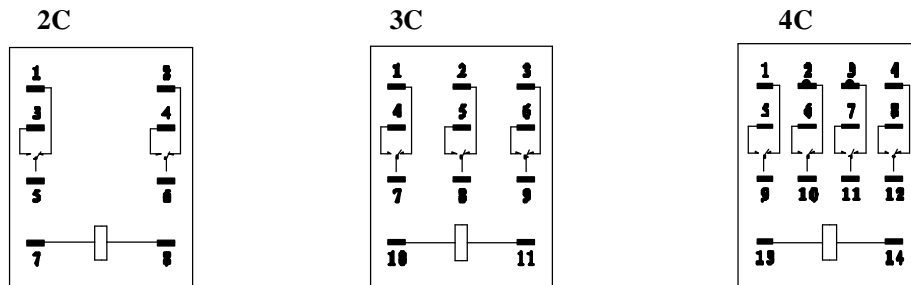

NRG52-3Pole Plug-in terminal

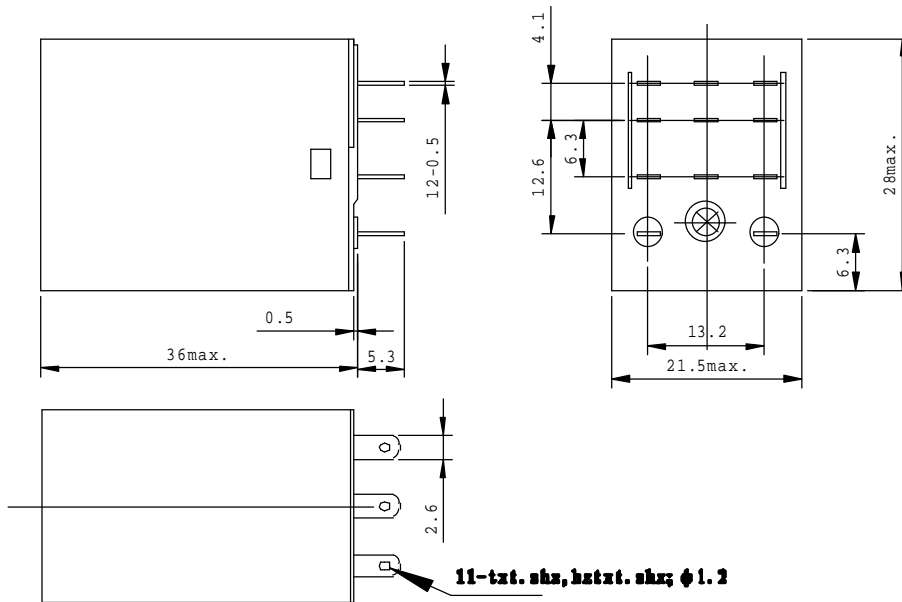

NRG52-4Pole Plug-in terminal

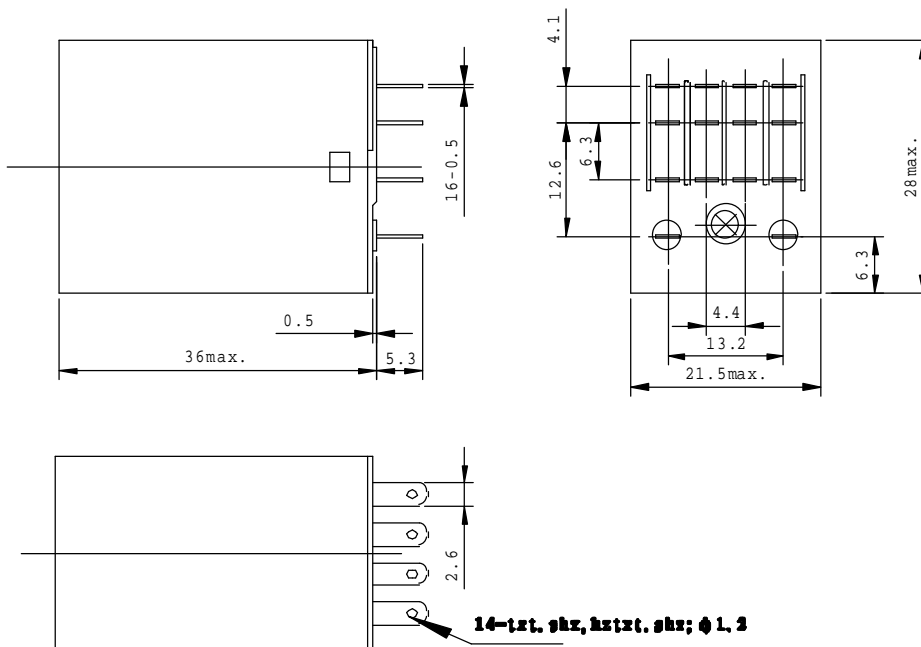

NRG52-2Pole P.C.B terminal
 NRG52-3Pole P.C.B terminal
 NRG52-4Pole P.C.B terminal

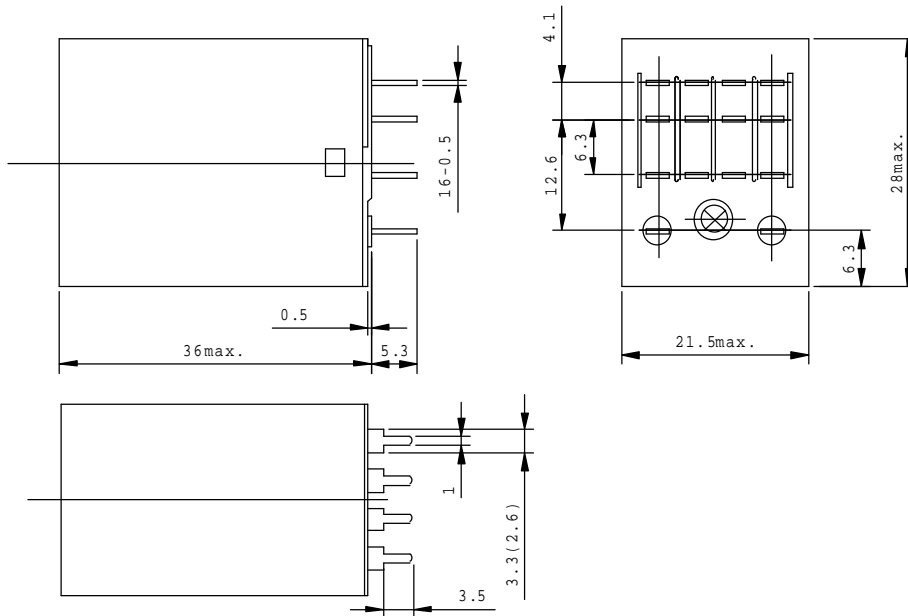

NRG52-2Pole Flange Case and Plug-in terminal
 NRG52-3Pole Flange Case and Plug-in terminal
 NRG52-4Pole Flange Case and Plug-in terminal

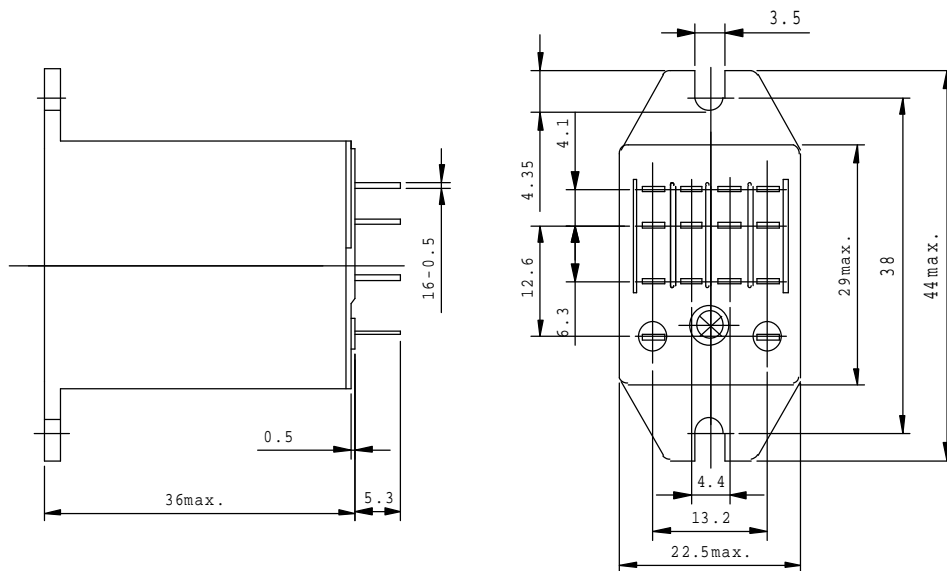

Mounting holes (Bottom view)

